

## 外形尺寸与工作范围

Appearance size and working scope

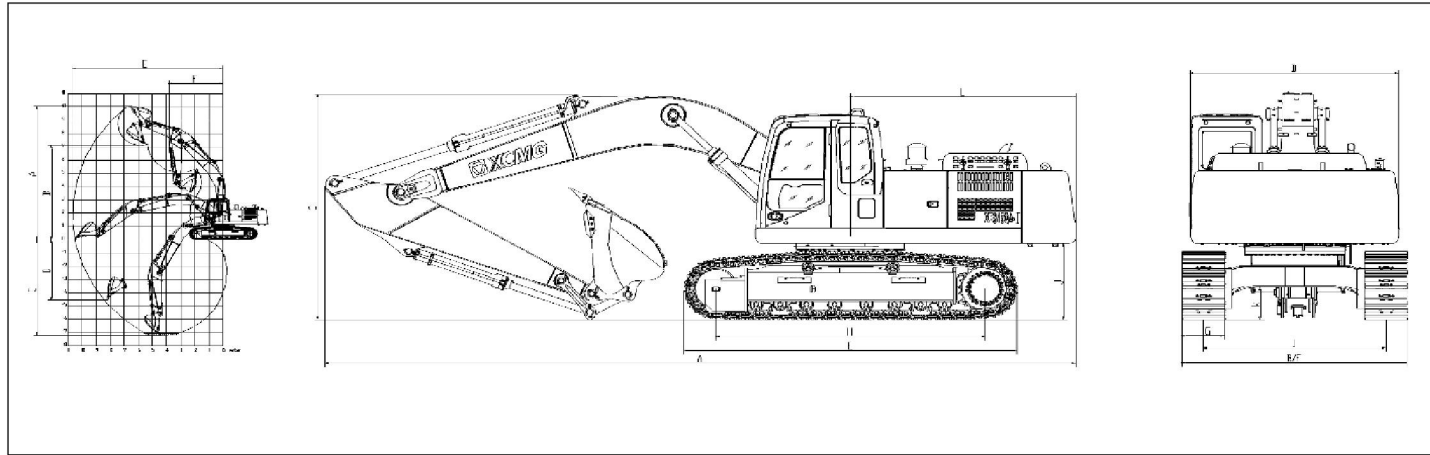

## 参数

Parameters

| 型号 Model              | 单位 Unit        | 参数 Parameter |
|-----------------------|----------------|--------------|
| 操作重量 Operating weight | kg             | 30800        |
| 铲斗容量 Bucket capacity  | m <sup>3</sup> | 1.4          |

| 发动机 Engine                  |        |             |
|-----------------------------|--------|-------------|
| 型号 Model                    | /      | CumminsQSB7 |
| 缸数 No. of cylinders         | /      | 6           |
| 发动机输出功率 Output power        | kW/rpm | 170/1900    |
| 最大扭矩 / 转速 Max. torque/speed | N.m    | 895/1700    |
| 排量 Displacement             | L      | 6.7         |

| 主要性能 Main performance      |       |         |
|----------------------------|-------|---------|
| 行走速度 Travel speed          | km/h  | 5.2/3.1 |
| 回转速度 Rotating speed        | r/min | 9.4     |
| 爬坡能力 Gradeability          | %     | 70      |
| 接地比压 Ground pressure       | kPa   | 59.5    |
| 铲斗挖掘力 Bucket digging force | kN    | 187     |
| 斗杆挖掘力 Arm crowd force      | kN    | 130     |

| 液压系统 Hydraulic system                 |       |                      |
|---------------------------------------|-------|----------------------|
| 主泵 Main pump                          | /     | K5V140DTP1Q9R-9N15-V |
| 主泵额定流量 Rated flow of main pump        | L/min | 2×251                |
| 主安全阀压力 Pressure of prime relief valve | MPa   | 32.4/34.3            |
| 先导系统压力 Pressure of pilot system       | MPa   | 3.9                  |

| 油类容量 Oil capacity              |   |     |
|--------------------------------|---|-----|
| 燃油箱容积 Fuel tank capacity       | L | 520 |
| 液压油箱容积 Hydraulic tank capacity | L | 270 |
| 发动机机油容量 Engine oil capacity    | L | 20  |

## 代理商 Agent

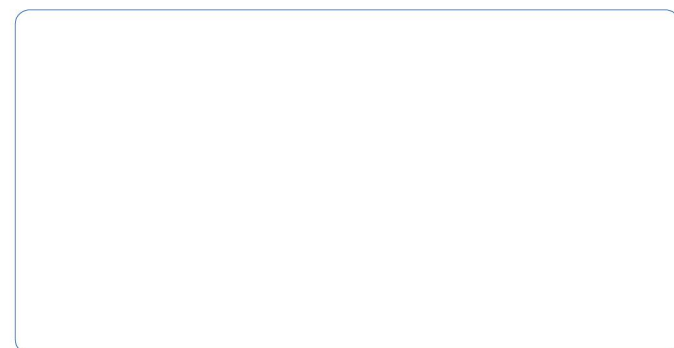

统一客服热线 Customer service hotline: 400-110-9999

| 型号 Model                               | 单位 Unit | 参数 Parameter |
|--|---------|--------------|
| 外形尺寸 Appearance size                   |         |              |
| A 总长 Overall length                    | mm      | 10645        |
| B 总宽 Overall width                     | mm      | 3190         |
| C 总高 Overall height                    | mm      | 3410         |
| D 转台宽度 Width of platform               | mm      | 2950         |
| E 履带长度 Length of crawler               | mm      | 4722         |
| F 底盘总宽 Overall width of chassis        | mm      | 3190         |
| G 履带宽度 Width of crawle                 | mm      | 600          |
| H 履带轴距 Track length on ground          | mm      | 3813         |
| I 轨距 Crawler gauge                     | mm      | 2590         |
| J 配重离地间隙 Clearance under counterweight | mm      | 1152         |
| K 最低离地间隙 Min. ground clearance         | mm      | 495          |
| L 尾部最小回转半径 Min. tail swing radius      | mm      | 3200         |

| 工作范围 Working scope                          |    |       |
|---|----|-------|
| A 最大挖掘高度 Max. digging height                | mm | 10100 |
| B 最大卸载高度 Max. dumping height                | mm | 7135  |
| C 最大挖掘深度 Max. digging depth                 | mm | 7245  |
| D 最大垂直挖掘深度 Max. vertical wall digging depth | mm | 4560  |
| E 最大挖掘半径 Max. digging reach                 | mm | 10665 |
| F 最小回转半径 Min. swing radius                  | mm | 3076  |

| 标配 Standard configuration |    |      |
|---------------------------|----|------|
| 动臂长度 Length of boom       | mm | 6200 |
| 斗杆长度 Length of arm        | mm | 3100 |

| 标配 Standard configuration |    |      |
|---------------------------|----|------|
| 动臂长度 Length of boom       | mm | 6200 |
| 斗杆长度 Length of arm        | mm | 3100 |

本产品随技术进步不断更新改进，如有修改，恕不另行通知。  
样本图片与实物不符的，以实物为准。

All the information, charts and standards in this brochure are the latest acquired upon publication. All information shall be subject to changes without additional notices.

If there is inconsistency between image and the actual product, the actual product shall govern.

**徐工集团挖掘机械事业部**  
XCMG EXCAVATOR MACHINERY BUSINESS DEPARTMENT

地址：中国江苏徐州经济开发区东环工业园28号  
Address: No.28 Donghuan Industrial Area Economic Development Zone of Xuzhou, Jiangsu, China.



# XE315QA-1 液压挖掘机

**厚积薄发**  
Spur with long accumulation

**超越经典**  
Beyond the classic

- 铲斗容量 Bucket capacity (m<sup>3</sup>): 1.4
- 操作重量 Operating weight (kg): 30800
- 额定功率 Output power (kW/rpm): 170/1900

**徐工集团挖掘机械事业部**  
XCMG EXCAVATOR MACHINERY BUSINESS DEPARTMENT